

C-7017

Sub. Code

11F

**COMMON FOR ALL U.G. DEGREE COURSES
EXAMINATION, NOVEMBER 2022**

First Year — First Semester

Part I — FRENCH

(2016 to 2018 onwards)

Duration : 3 Hours

Maximum : 75 Marks

Part A

(10 × 2 = 20)

Answer **all** questions.

1. La capitale de la France C'est _____ (Berlin/Paris)
2. Pour saluer le matin _____ (Bonfour/Merci)
3. Pour Lundi en englose _____ (Tuesday/Monday)
4. Nous _____ (I/we)
5. Name two monuments in France ?
6. Why is Paris is known as “VILLE LUMIERE”?
7. What is the currency of France ?
8. Why is the flag of France called “Tricolore”?
9. Why is France referred to as the “Hexagone”?
10. Ecrivez les nombres en lettres :
 - (a) 100 _____
 - (b) 200 _____

Part B

(5 × 5 = 25)

Answer **all** questions.

11. (a) Ecrivez les jours de la remanie.

OU

- (b) Ecrivez les mois de l'annee.

12. (a) Conjuguez le verbe "etre".

OU

- (b) Conjuguez le verbe "avoir".

13. (a) Conjuguez le verbe "Rester".

OU

- (b) Conjuguez le verbe "S"applier.

14. (a) Lister deractio en français.

OU

- (b) Liste hors saison en français.

15. (a) Enumerer Cinq Legumes en français.

OU

- (b) Enumerer Cinq fruits en français.

Part C

(3 × 10 = 30)

Answer **all** questions.

16. Ecrivez les nombres

- (a) 1 to 25

OU

- (b) 25 × 50

17. (a) Decrit un paya “france”.

OU

(b) Ecrivez dix couleurs en française.

18. (a) Presente toi en minimum 03 paragraphe.

OU

(b) Decrivez votre jeu préféré au minimum 03 paragraphe.

C-7018

Sub. Code

11H

U.G. DEGREE EXAMINATION, NOVEMBER 2022

First Year/First Semester

Part I – Hindi

STORY, NOVEL, GRAMMAR AND TRANSLATION – I

(Common for all U.G. Degree Courses/First Semester)

(2016 to 2018 onwards)

Duration : 3 Hours

Maximum : 75 Marks

Part A

(10 × 2 = 20)

सभी प्रश्नों के उत्तर संक्षेप में लिखिए।

1. आनन्दी ने लालबिहारी की क्या शिकायत की थी?
2. रामू की माँ ने क्यों पंडितजी के पैर पकड़े?
3. लहनासिंह ने नकली लपटन को कैसे पहचाना?
4. मोहनलालजी महतो 'वियोगी' का संक्षिप्त परिचय दीजिए।
5. उदयभानुलाल और कल्याणी के बीच झगड़ा क्यों हुआ?
6. निर्मला से रुक्मणि का व्यवहार कैसा था?
7. नयनसुखराम ने तोताराम को क्या सलाह दिया?
8. कृष्णा की शादी किससे हुई ? और क्यों?

9. लिंग बदलिए।
(a) मालिक (b) कवि
(c) ठाकुर (d) विधवा
10. वचन बदलिए
(a) लड़की (b) आँख
(c) जू (d) माला

Part B

(5 × 5 = 25)

सभी प्रश्नों के उत्तर दीजिए।

11. (a) बेनिमाधव सिंह से श्रीकंठ का व्यवहार कैसा था?
या
(b) मिसरानी का चरित्र-चित्रण कीजिए।
12. (a) 'उसने कहा था' - इस कहानी में किसने किससे क्या कहा था?
या
(b) 'पाँच मिनट' कहानी का संदेश क्या है?
13. (a) मंसाराम की मृत्यु का जिम्मेदार कौन हैं? स्पष्ट कीजिए।
या
(b) भुवनमोहन सिन्हा ने क्यों आत्महत्या कर लिया?
14. (a) सियाराम साधू के जाल में कैसे फँस गया?
या
(b) रंगीलीबाई का चरित्र-चित्रण कीजिए।

15. (a) सर्वनाम किसे कहते हैं? उनके भेदों को उदाहरण सहित समझाइए।

या

(b) पुल्लिंग से स्त्रीलिंग बनाते के नियमों को उदाहरण सहित समझाइए।

Part C

(3 × 10 = 30)

सभी प्रश्नों के उत्तर विस्तार से लिखिए।

16. (a) प्रायश्चित्त कहानी का सारांश लिखकर विशेषताएँ बताइए।

या

(b) निर्मला का चरित्र-चित्रण कीजिए।

17. (a) संज्ञा किसे कहते हैं? उनके भेदों को उदाहरण सहित समझाइए।

या

(b) विशेषण की परिभाषा देकर उसके भेदों को उदाहरण सहित समझाइए।

18. (a) पाँच मिनट कहानी का सारांश लिखिए।

या

(b) अंग्रेजी में अनुवाद कीजिए।

वही समाज श्रेष्ठ है और वही राष्ट्र सुखी है जिसकी जनता का चरित्र अच्छा हो। आज के बालक कल के नागरिक हैं। इसलिए उनके चरित्र का निर्माण करना समाज और राष्ट्र का पहला कर्तव्य है।

में पिताजी की बहुत इज्जत करता था। मैं उन्हें बल, साहस और होशियारी की मूर्ति समझता था और दूसरों के मुकाबले में उन्हें बहुत ही ऊँचा और बड़ा-चढ़ा पाता था।

कौए के संबन्ध में एक रोचक कथा है। कहते हैं, एक बार वह कोयल का बाना धारण करके चारों ओर लोगों की आँखों में धूल झोंकता फिरा। कई मास ऐसे ही बीते। जब वसंत आया, तो असली कोयल ने तो पंचम स्वर में गाना आरंभ कर दिया, पर कोयल चुप रहा।

C-5667

Sub. Code

11T

B.Sc./B.B.A. DEGREE EXAMINATION, APRIL 2022.

First Year / First Semester

Part – I

தமிழ்ச்செம்மொழியும் தமிழர்களின் பன்முகத்திறனும்

(Common for all U.G. Degree Courses)

(2016 to 2018 onwards)

Duration : 3 Hours

Maximum : 75 Marks

பகுதி அ

(10 × 2 = 20)

அனைத்து வினாக்களுக்கும் விடையளிக்கவும்.

1. ஓட்டுநிலை மொழி என்றால் என்ன?
2. தமிழின் செம்மொழித் தகுதிகளைச் சான்றுகளுடன் எடுத்துக் காட்டி விளக்கியவர் யார்?
3. செம்மொழி தகுதிபெற்றக் காப்பியங்கள் கூறுக.
4. தழை ஆடை என்பதென்ன?
5. கழல் என்னும் அணிகலன் பண்டைகாலத்தில் இருந்தமைக்கு இலக்கியச் சான்று ஒன்று காட்டுக.
6. குகை காவியங்கள் பற்றிக் குறிப்புரைக்க.
7. களிமண் சிற்பங்கள் பற்றிக் கூறுக.
8. பண்டைக் காலத்தில் காணப்பட்ட வாணிபப் போக்குவரத்து முறைகள் இரண்டினைக் கூட்டுக.
9. மருந்துகளால் பெயர்பெற்ற இரண்டு அறநூல்கள் தருக.
10. விருந்தோம்பல் குறித்த வள்ளுவரின் சிந்தனை ஒன்றைத் தருக.

அனைத்து வினாக்களுக்கும் விடை தருக.

11. (அ) இந்தியச் செம்மொழிகள் பற்றி எடுத்துரைக்க.

(அல்லது)

(ஆ) தமிழ்ச் செம்மொழி இலக்கியங்கள் வரிசைப்படுத்தி அத்தகுதி பெற்றமைக்கானச் காரணங்களை சுருக்கி விளக்குக.

12. (அ) நடலாடை , பட்டாடைக் குறித்த இலக்கியப் பதிவுகளைத் தருக.

(அல்லது)

(ஆ) ஆடைக்கும் பண்பாட்டிற்கும் உள்ள தொடர்பு குறித்து எடுத்துரைக்க.

13. (அ) காப்பியங்கள் காணலாகும் அணிகலன்கள் பற்றிய பதிவுகளைத் தருக.

(அல்லது)

(ஆ) பெண்கள் அணியும் அணிகலன்களாக இலக்கியங்கள் வழி அறியப்படுவனவற்றைச் சான்றுடன் தருக.

14. (அ) இலக்கியங்கள் வழி அறியலாகும் சிற்பக்கலை குறித்து எடுத்துரைக்க.

(அல்லது)

(ஆ) கட்டடக்கலைக்கும் காப்பியங்கள் சான்றுகளை எடுத்துரைக்க.

15. (அ) பண்டை இலக்கியங்கள் வழி அறியப்படும் மருத்துவக் குறிப்புகளைத் தருக.

(அல்லது)

- (ஆ) பண்டைத் தமிழ் மக்கள் போற்றிய விருந்தோம்பலை விரித்துரைக்க.

பகுதி இ

(3 × 10 = 30)

அனைத்து வினாக்களுக்கும் விடை தருக.

16. (அ) தமிழின் சிறப்புகளையும், அதன் இலக்கிய வளமை குறித்தும் கட்டுரை வரைக.

(அல்லது)

- (ஆ) தமிழ்ச் செம்மொழி நூல்களின் தனித்தன்மைகளை விளக்கி ஆராய்க.

17. (அ) ஆடை வகைகளை இலக்கியச் சான்று காட்டி விரித்துரைக்க.

(அல்லது)

- (ஆ) தமிழர்களின் அணிகலன் பயன்பாடு குறித்துக் கட்டுரைக்க.

18. (அ) இசைக்கலை குறித்துச் செம்மொழிச் இலக்கியக் பதிவுகள் சான்றுடன் விளக்கியுரைக்க.

(அல்லது)

- (ஆ) இலக்கியங்கள் வழி அறியலாகும் பண்பாடு பழக்க வழக்கங்கள் பற்றிக் கட்டுரை வரைக.

C-5670

Sub. Code

91411/12

**Common for all U.G. B.Sc./B.B.A. DEGREE
EXAMINATION, APRIL 2022**

First Year/First Semester

English

**Part II – ENGLISH PROSE AND COMMUNICATION
SKILLS**

(2016 to 2018 onwards)

Duration : 3 Hours

Maximum : 75 Marks

Part A

(10 × 2 = 20)

Answer **all** questions.

1. What is vocational education?
2. What is it that Indira Gandhi does not demand?
3. What did Stevenson ride on?
4. What was the boy's reaction to the punishment?
5. What was remarkable about Ernest Thompson Seton's *Wild Animals I have Known*?
6. What are the tree visions that Sarojini Naidu talks of?
7. He _____ my uncle yesterday. (Use correct form of verb)
8. Define Noun.
9. Seenu is a boy _____ poor family. (use appropriate preposition)
10. _____ you like to have tea or coffee? (Use correct auxiliaries)

Part B

(5 × 5 = 25)

Answer **all** questions, choosing either (a) or (b).

11. (a) Write a short note on how to attain Excellence I education emphasized by Livingstone.

Or

- (b) Substantiate Indira Gandhi's view that the youth are the backbone of India.

12. (a) What is the usefulness of forming habits?

Or

- (b) How does the teacher try to repair the damage done and with what result?

13. (a) What books did Margaret Atwood enjoy reading?

Or

- (b) What does Sarojini Naidu say about the vision of patriotism?

14. (a) Write a short note on types of sentences.

Or

- (b) Fill in the blanks using Present Perfect Continuous Tense:

- (i) The _____ (work) all day.
(ii) He eyes were red because she _____ (cry).
(iii) She _____ (sing) upto that morning.
(iv) They _____ (wait) for her since 8 0' clock.
(v) Mani _____ (read) this book for the past three hours.

15. (a) Write the correct sentence pattern.
- (i) I finished the work.
 - (ii) She worked in a reputed company.
 - (iii) Our headmaster Sideline was a lending library.
 - (iv) They made David Chairman of the Rotary Club.
 - (v) We wish you happy new year.

Or

- (b) Fill in the blanks using appropriate Prepositions:
- (i) He came _____ the office _____ a big hurry.
 - (ii) We drove _____ the store.
 - (iii) Four armed men held _____ the bank.
 - (iv) We finally lived _____ that incident.

Part C

(3 × 10 = 30)

Answer **all** questions.

16. (a) What, according to Livingstone, are the essentials of education?

Or

- (b) Write an essay on personality of Indira Gandhi as revealed in her speeches.

17. (a) What are Gardiner's views on the desirability or otherwise of forming habits?

Or

- (b) Write an essay in 500 words about the relationship between the rich student and the poor teacher.

18. (a) Write an essay on present tenses.

Or

(b) Fill in the blanks with correct preposition.

Nehru was called _____ to say a few words
_____ the occasion _____ the
assassination _____ Gandhi _____ an
utter sense _____ shame, Nehru expressed
his regret _____ the failure out country
_____ give protection _____ the life
_____ this great man, as well as that
_____ many an innocent man, woman and
child.

C-7021

Sub. Code

21F

B.Sc./B.B.A. DEGREE EXAMINATION, NOVEMBER 2022.

Second Year — Second Semester

Part I — FRENCH

(Common for All UG Degree Courses)

(2016 to 2018 onwards)

Duration : 3 Hours

Maximum : 75 Marks

Part A

(10 × 2 = 20)

Answer **all** questions.

1. Comment vas-tu?
2. Ça fait longtemps, comment vas-tu?
3. Comment t'appelles-tu?
4. Je m'appelle Peter. Comment t'appelles-tu?
5. Quel est ton numéro de téléphone?
6. J'aimerais t'appeler. Quel est ton numéro de téléphone ?
7. Quel âge as-tu?
8. Tu dois avoir 21 ans pour rentrer ici. Quel âge as-tu ?
9. D'où venez-vous?
10. Vous semblez être britannique. D'où venez-vous?

Part B

(5 × 5 = 25)

Answer **all** questions.

11. (a) énumérer 05 légumes en français.

Ou

- (b) Lister 05 fruits en français.

12. (a) Écrire la saison en français.

Ou

- (b) Écrire les instructions en français.

13. Écrire les noms de pays en français :

- (a) (i) India
(ii) Japan
(iii) China
(iv) Italy
(v) Rome.

Ou

- (b) (i) Denmark
(ii) London
(iii) Australia
(iv) Europe
(v) Sweden.

14. Écrire des nombres en français :

- (a) (i) 100
(ii) 200
(iii) 300
(iv) 400
(v) 500.

Ou

- (b) (i) 50
- (ii) 65
- (iii) 70
- (iv) 80
- (v) 90.

15. (a) Ecrire les membres de la famille en français.

Ou

(b) Ecrire les jours d'une semaine en français.

Part C (3 × 10 = 30)

Answer **all** questions.

16. (a) Ecrire des alphabets en français.

Ou

(b) Ecrire les mois de l'année en français.

17. (a) Ecrivez les nombres de 1 à 25 en français.

Ou

(b) Ecrivez les nombres de 25 à 50 en français.

18. (a) Présente-toi en français.

Ou

(b) Expliquez votre ville natale en français.

C-7022

Sub. Code

21H

U.G. DEGREE EXAMINATION, NOVEMBER 2022

Second Year/Second Semester

Part I – Hindi – II

HINDI II — PROSE, GRAMMAR AND
TRANSLATION – II

(Common for all U.G. Degree Courses)

(2016 to 2018 onwards)

Duration : 3 Hours

Maximum : 75 Marks

Part A

(10 × 2 = 20)

सभी प्रश्नों के उत्तर संक्षेप में लिखिए।

1. वह कौन-सी वस्तु है जो विभिन्नता में एकता बनाये हुए है?
2. घृणा और भय में क्या सम्बन्ध है?
3. लेखक ने रजिया को अंतिम बार किस रूप में देखा?
4. 'मक्रील' कहानी की भाषा पर प्रकाश डालिए।
5. 'बहता पानी निर्मला' पाठ का निष्कर्ष क्या है?
6. गाँधीजी के प्रधान सिद्धांत क्या है?
7. यात्रा के कौन-कौन तरीके हैं? वे क्या है?
8. भारत के सम्बन्ध में गाँधीजी की कल्पना क्या थी?

9. चुड़िहारिन के पेशे में क्या विशेषतायें होनी चाहिए?
10. घृणा किस प्रकार की मनोवृत्ति है और यह किसके लिए सिरजी गयी है?

Part B

(5 × 5 = 25)

सभी प्रश्नों के उत्तर लिखिए।

संदर्भ सहित व्याख्या कीजिए।

11. (a) हमारी सामूहिक चेतना ऐसे नैतिक आधार पर ठहरी हुई है, जो पहाड़ों से भी मजबूत, समुद्रों से भी गहरी और आकाश से भी अधिक व्यापक है।

या

- (b) कौन नहीं जानता कि वही विष, जो प्राणों का नाश कर सकता है, प्राणों का संकट भी दूर कर सकता है।

12. (a) और गोरे चेहरे तो मिले हैं, किंतु इनकी आँखों में जो एक अजीब किस्म का नीलापन दिखा, वह कहाँ?

या

- (b) समीप खड़ी एक युवती को देख, भद्रता से टोपी छूते हुए उसने पूछा, 'आप भी इसी होटल में ठहरी हैं'।

13. (a) 'जनाब, अपना बोरिया-बिस्तर समेटिका और ज़रा चलते-फिरते नज़र आइये' यह आप का अपमान नहीं है।

या

- (b) वे झोपडियों में रहते, नंगे पैर चलते, एक धोती-भर पहनते।

व्याकरण

14. (a) अपूर्ण क्रिया से क्या मतलब है? उदाहरण दीजिए।

या

- (b) काल की दृष्टि से क्रिया के भेदों को उदाहरण सहित स्पष्ट कीजिए।

15. (a) 'ने' विधि का प्रयोग समझाइए।

या

(b) संभाव्य भविष्यत् काल किन अर्थों में प्रयुक्त होता है?

Part C

(3 × 10 = 30)

सभी प्रश्नों के उत्तर दीजिए। उत्तर विस्तार से हो।

16. (a) 'जीवन में घृणा का स्थान' पाठ का सारांश लिखिए।

या

(b) 'राष्ट्रपिता महात्मा गाँधी' पाठ का सारांश लिखिए।

17. (a) 'क्रिया विशेषण' किसे कहते हैं? अर्थ के अनुसार इसके कितने भेद हैं? उदाहरण सहित समझाइए।

या

(b) 'कारक' किसे कहते हैं? उनके भेदों को उदाहरण सहित समझाइए।

18. हिन्दी में अनुवाद कीजिए।

(a) Many people say that the climate of England and that of Kodaikanal are almost the same. You do not have as much heat at Kodaikanal, as you have at Ooty during the day-time. The temperature at night is also not so cold as at Ooty. The natural scenery of Kodaikanal is just like that of England. But on account of better travel facilities more people go to Ooty. Hence there is more calm at Kodaikanal than at Ooty.

या

- (b) Everyone has a right to have enough good food to eat, if he earns it by his work. Here the state has a great responsibility. It must try to find food for all the people, to be sold at prices which they can afford to pay. The Government should, therefore, try to improve food production by helping the farmers in many ways.
-

C-7020

Sub. Code

21T

UG DEGREE EXAMINATION, NOVEMBER 2022

Second Year / Second Semester

Part I – இலக்கணமும் படைப்பிலக்கியமும்

Tamil

Common for all UG Degree Course

(2016 to 2018 onwards)

Duration: 3 Hours

Maximum : 75 Marks

பகுதி அ

(10 × 2 = 20)

அனைத்து வினாக்களுக்கு விடையளி.

1. முதலெழுத்துக்கள் என்பவை எவை?
2. மொழியிறுதி எழுத்துக்கள் யாவை?
3. புதுக்கவிதையின் இலக்கணம் பற்றி வரைக.
4. மீராவின் கவிதைத் திறன் குறித்துரைக்க.
5. தமிழ்ச் சிறுகதைத் தோற்றம் குறித்து எழுதுக.
6. அசோகமித்ரனின் சிறுகதைப் பாங்கு யாது?
7. 'வலைப்பூ' - விளக்குக.
8. கவிதையின் அமைப்பு பற்றி எழுதுக.
9. இணையமும் தமிழும் - குறிப்பு வரைக.
10. படைப்பில் – கற்பனை பெறும் இடம் யாது?

அனைத்து வினாக்களுக்கு விடையளி.

11. (அ) சார்பெழுத்துக்களின் வகைகளை விவரி.

(அல்லது)

(ஆ) வல்லினம் மிகா இடங்களைக் காட்டுக.

12. (அ) மு. மேத்தா வைகறை கவிதையில் உரைப்பனவற்றைத் தருக.

(அல்லது)

(ஆ) வைரமுத்துவின் கவிதைச் சிறப்பினைத் தருக.

13. (அ) சாபவிமோசனம் கதைக் கருவை விவரி.

(அல்லது)

(ஆ) பரிசு கதையில் காணப்படும் சமூக உணர்வுகளைத் தெளிவுபடுத்துக.

14. (அ) மின் நூலகம் குறிப்பு வரைக.

(அல்லது)

(ஆ) இணையமும் தமிழ் வளர்ச்சித் துறையும் பற்றி விளக்குக.

15. (அ) இன்றைய சிறுகதைகளின் நிலை யாது?

(அல்லது)

(ஆ) இணைய வளர்ச்சி குறித்து ஆய்க.

பகுதி இ

(3 × 10 = 30)

அனைத்து வினாக்களுக்கு விடையளி.

16. (அ) உடம்படுமெய் பற்றி விவரிக்க.

(அல்லது)

(ஆ) மொழிமுதல் எழுத்துக்களைச் சான்றுடன் விளக்குக.

17. (அ) சிறுகதை வளர்ச்சி குறித்து மதிப்படுக.

(அல்லது)

(ஆ) புதுக்கவிதையின் தோற்றமும் வளர்ச்சியும் பற்றி ஆய்க.

18. (அ) மின்னஞ்சல் என்பதனை விளக்குக.

(அல்லது)

(ஆ) 'மூத்தோர் சொல்' எனும் தலைப்பில் சிறுகதை படைக்க.

C-5674

Sub. Code

91421/22

B.Sc./B.B.A. DEGREE EXAMINATION, APRIL 2022

Second Year/Second Semester

Common for all UG Degree Courses

**Part II – ENGLISH - PROSE, EXTENSIVE READING
AND COMMUNICATION SKILLS**

(2016 to 2018 onwards)

Duration : 3 Hours

Maximum : 75 Marks

Part A

(10 × 2 = 20)

Answer **all** questions.

1. Kalam is proud of having worked with three great men. Who are they?
2. What kind of society did we have in the pre-war period?
3. What are the two ways in which science benefits man?
4. Why does Nehru regard Gandhi as the sun?
5. What experiences do students in schools and colleges have in arguing?
6. What was the agreement between Bob and Jimmy twenty years before, when they parted?
7. How did the Quick man explain it away?

8. What did the stranger want to know?
9. What are the types of adjective clause?
10. What is Sub-ordinate Conjunctions? Give example.

Part B

(5 × 5 = 25)

Answer **all** questions.

11. (a) What does Kalam say about the passivity of Indians?

Or

- (b) What are the contradictory views of Plato on the artist's role in society?

12. (a) How does Nehru reconcile himself with Gandhi's death?

Or

- (b) What is Lynd's conversion to socialism and nationalism?

13. (a) How does the true friendship reflect in *After Twenty Years*?

Or

- (b) How did the conjuror take his revenge on the Quick Man?

14. (a) How did the father test the skills of his sons?

Or

- (b) How do Phrase help in making of Simple sentence?

15. (a) Jot down the changes/ rules while transforming the Exclamatory sentences of Direct speech into Indirect speech.

Or

- (b) Write a paragraph on the 'Formation of Positive and Superlative Degrees'.

Part C (3 × 10 = 30)

Answer **all** questions.

16. (a) Write an essay on Kalam's three visions.

Or

- (b) What does Holt say about ballet training? What does he deduce from it?

17. (a) How are the two friends contrasted?

Or

- (b) Elucidate how the conjuror's tricks and the Quick Man's deflationary comments for it.

18. (a) What are the kinds of Conjunctions? Explain in detail.

Or

- (b) What are the Degrees of comparison? Explain with examples.

C-7024

Sub. Code

31

**COMMON FOR ALL U.G. DEGREE COURSES
EXAMINATION, NOVEMBER 2022**

Third Semester/Third Year

Part II — ENGLISH

COMMUNICATIVE SKILLS

(2016 to 2018 onwards)

Duration : 3 Hours

Maximum : 75 Marks

Part A

(10 × 2 = 20)

Answer **all** questions.

1. What is meant by non-verbal communication?
2. How do you manage noise situation on your presentation?
3. Frame Question for the following sentences.
 - (a) I would like to become an investigating agent.
 - (b) He had worked here for the past ten years.
4. Define Homophones.
5. Give two example for wrong position of adverb.
6. What is the main use of interjections?
7. What are called consonants?
8. What is meant by rising intonation?
9. What are the benefits of skimming?
10. Mention any two mechanics of good handwriting.

Part B

(5 × 5 = 25)

Answer **all** questions.

11. (a) Write a paragraph on non-verbal communication.

Or

- (b) What are the ways of challenging the barriers of communication?

12. (a) Write a short note on homophones with examples.

Or

- (b) Change the following active sentences into passive voice.

(i) I did not beat her.

(ii) I will never forget this experience.

(iii) Mother made a cake yesterday.

(iv) The tiger was chasing the deer.

(v) She has written a novel.

13. (a) Write a note on wrong position of adverbs.

Or

- (b) Write in short on some confused use of adjectives.

14. (a) Write a note on primary stress with proper examples.

Or

- (b) Describe the general use of intonation.

15. (a) What are the uses of silent reading?

Or

(b) What is the role of SQ3R in communication?

Part C (3 × 10 = 30)

Answer **all** questions.

16. (a) Discuss in detail on effective ways of communication.

Or

(b) Write an essay on barriers to communication and effective ways to overcome the barriers.

17. (a) Write briefly on the following :

- (i) Phrasal verbs
- (ii) Conditional clause.

Or

(b) Write an essay on common confusions of parts of speech.

18. (a) Write an essay on the types of reading and developing reading strategies.

Or

(b) Explain briefly on mechanics of good handwriting.

C-7025

Sub. Code

41

U.G. DEGREE EXAMINATION, NOVEMBER 2022

Fourth Semester

Part II — English

EMPLOYABILITY SKILLS

(Common for all UG Degree Courses)

(2016 to 2018 onwards)

Duration : 3 Hours

Maximum : 75 Marks

Part A

(10 × 2 = 20)

Answer **all** following questions.

1. How do you introduce a person in a public meeting?
2. What is meant by head to foot appearance?
3. Why do we write letters?
4. What are the basic elements for writing job application?
5. What are the different types of greetings?
6. Define portfolio.
7. What is meant by oral composition?
8. What are the three main parts of a composition?
9. Define kinesics.
10. What are the technical elements for using video aids for communication?

Part B

(5 × 5 = 25)

Answer **all** questions.

11. (a) Write in short on telephonic etiquettes.

Or

- (b) Describe in short on head to foot appearance.

12. (a) What are the important aspects on resume writing?

Or

- (b) Write a letter to the editor about your street road's poor condition.

13. (a) Write in short on merits of e-mail.

Or

- (b) Write in short on developing topic sentences into paragraph.

14. (a) Write briefly on written composition.

Or

- (b) Write a paragraph on 'e-waste'.

15. (a) Write in short on gesture.

Or

- (b) Describe in short on the uses of visual aids.

Part C

(3 × 10 = 30)

Answer **all** questions.

16. (a) Write an essay on interview techniques and head to foot appearance while attending interview.

Or

- (b) Write a letter to the manager for the post of sales officer along with your resume.

17. (a) Write an essay on preparing portfolios and its various types.

Or

- (b) Write a review for two books that you recently read.

18. (a) Read the passage below and then answer the following questions.

One day, my father talked to his phone for a long time his airtime got used up before he could end his talk. He was conversing with his workmate, Mr. Obadiya. He decided to send me to buy more airtime.

Using My bicycle, I rode as fast as a horse. I returned within ten minutes with airtime. When I reached home, I found my father busy listening to the news on radio. He was so attentive that he did not want any disturbance. He therefore, gave me the mobile phone to load the airtime for him.

I was excited because I was going to do so for the first time. I got the airtime card and scratched it. Since I did not know what to do after scratching, I opened the phone. Then I took it to my father thinking I had done the right thing.

My father immediately tried to call his friend. He dialed repeatedly but the call could not go through. "Have you loaded the airtime"? he asked me. I responded happily that I had loaded it. As he removed the battery, the airtime card dropped on the floor. "Oh my son! you did not know how to load airtime !" he laughed. I was disappointed that I did not load airtime for my father. He realized that I was sad. He held me in his arms and said, "don't worry my son. Let's do it together". Then he loaded as I was watching. I was very happy to learn how to load airtime.

Questions for composition :

- (i) What happened to the airtime of the father?
- (ii) Why did the writer go to the shop?
- (iii) When the writer brought airtime, what was his father doing?
- (iv) Why was the writer excited?
- (v) Why did the writer get disappointed?

Or

- (b) Write an essay on different types of visual aids.

C-7016

Sub. Code

11T

U.G. DEGREE EXAMINATION, NOVEMBER 2022.

First Year / First Semester

Tamil – Part-I

தமிழ்ச் செம்மொழியும் தமிழர்களின் பன்முகத்திறனும்

(Common for all UG Degree courses)

(2016 to 2018 onwards)

Duration : 3 Hours

Maximum : 75 Marks

பகுதி அ

(10 × 2 = 20)

அனைத்து வினாக்களுக்கும் விடையளிக்கவும்.

1. தனிநிலைமொழி என்றால் என்ன?
2. தமிழைச் செம்மொழி என்று முதலில் கூறிய வெளிநாட்டு அறிஞர் யார்?
3. செம்மொழி நூல்களில் உள்ள இலக்கணநூல்களைக் கூறுக.
4. வண்ண ஆடை என்பதென்ன?
5. குழந்தைகளின் அணிகலன்களைக் குறிப்பிடும் இலக்கியச்சான்று ஒன்று காட்டுக.
6. தமிழ் இலக்கியங்கள் காட்டும் இசைக்கருவிகள் இரண்டினைச் சுட்டுக.
7. நடுகல் - குறிப்பு வரைக.
8. நாள், கோள் பற்றிய நம்பிக்கைகள் பண்டைக் காலத்தில் இருந்தமைக்குச் சான்று ஒன்று காட்டுக.

9. உடற்பயிற்சி பற்றிக் கூறும் அறநூலைச் சுட்டுக.

10. புல்லரிசி என்பதென்ன?

பகுதி ஆ

(5 × 5 = 25)

அனைத்து வினாக்களுக்கும் விடை தருக.

11. (அ) மொழிக்குடும்பங்கள் பற்றி எடுத்துரைக்க.

(அல்லது)

(ஆ) செம்மொழிக்களைத் தகுதிகளை விரித்துரைக்க.

12. (அ) ஒற்றை ஆடை, இரட்டை ஆடை, என்பதென்ன? சான்றுடன் விளக்குக.

(அல்லது)

(ஆ) காலத்திற்கு ஏற்ற உடை என்பது குறித்து எடுத்துரைக்க.

13. (அ) சங்க இலக்கியங்கள் வழி அறியப்படும் அணிகலன்களுக்குச் சான்று காட்டி விரித்துரைக்க.

(அல்லது)

(ஆ) ஆண்கள் அணியும் அணிகலன்களாக இலக்கியங்கள் குறிப்பிடுவற்றைச் சான்றுடன் எடுத்துரைக்க.

14. (அ) ஒவியக்கலை பண்டைக்காலத்தில் சிறப்புற்றிருந்தமைக்கு இலக்கியச் சான்று காட்டுக.

(அல்லது)

(ஆ) சிலம்பில் மாதவி ஆடும் ஆடல்களை விரித்துரைக்க.

15. (அ) செம்மொழி இலக்கியங்களில் காணலாகும் அறிவியல் சிந்தனைகள் எடுத்துரைக்க.

(அல்லது)

(ஆ) இலக்கியங்கள்வழி அறியலாகும் நீர்மேலாண்மை குறித்து எடுத்துரைக்க.

அனைத்து வினாக்களுக்கும் விடை தருக.

16. (அ) தமிழன் தொன்மை குறித்துக் கட்டுரைக்க.

(அல்லது)

(ஆ) சங்க இலக்கியங்கள் செம்மொழித் தகுதி பெற்றிருப்பதனைச் சான்றுடன் நிறுவுக.

17. (அ) பண்பாட்டைப் போற்றுவதில் செம்மொழி இலக்கியங்கள் பெறும் இடம்குறித்துக் கட்டுரை வரைக.

(அல்லது)

(ஆ) இலக்கியங்களில் ஆடைகள் - கட்டுரை வரைக.

18. (அ) அணிகலன்கள் பற்றிய பழந்தமிழ் இலக்கியப் பதிவுகளைச் சான்றுடன் விளக்கி வரைக.

(அல்லது)

(ஆ) நடனக்கலை சிறப்புற்றிருந்தமைக்குச் சிலப்பதிகாரம் சான்றாதலை விளக்கியுரைக்க.

C- 7019

Sub. Code

91411/12

U.G. DEGREE EXAMINATION, NOVEMBER 2022

First Year / First Semester

Part II — English

PROSE AND COMMUNICATION SKILLS

(Common for All U.G. Degree Courses)

(2016 to 2018 onwards)

Duration : 3 Hours

Maximum : 75 Marks

Part A

(10 × 2 = 20)

Answer **all** questions.

1. Who is compared to the man who stumbles through his lessons?
2. What are the leadership quality according to Indira Gandhi?
3. Life is a —————
4. What is the main theme of the story “Crime and Punishment”?
5. Name the book which is about recipes as mentioned by Atwood?
6. What is the duty of each community in the view point of Sarojini Naidu?
7. Define Simple Present Tense.

8. Fill in the blanks with correct adjectives :

(a) Elephant is the ——— animal.

(b) She is a ——— lady.

9. Define definite article.

10. Fill in the blanks using correct modals :

(a) ——— I go?

(b) He ——— follow the rules.

Part B

(5 × 5 = 25)

Answer **all** questions.

11. (a) Write a short note on quality education leads to attain excellence.

Or

(b) Why does Indira Gandhi insist that youth are the backbone of India?

12. (a) Why was Balfour organized when he had to make a speech?

Or

(b) Describe the relationship between the student and the teacher.

13. (a) Why did Atwood prefer animal stories?

Or

(b) What does Sarojini Naidu say about the vision of patriotism?

14. (a) Explain the uses of simple past and past continuous Tense with examples.

Or

(b) What is Noun? What are the types of Nouns? Explain.

15. (a) Identify the pattern of the following sentences :

- (i) I was working in my father's company.
- (ii) Quality education is a must one.
- (iii) He bought many books about the country.
- (iv) The men have worked for five hours.
- (v) I will meet you there in a moment.

Or

(b) Fill in the blanks with the correct article :

- (i) I saw ——— tiger.
- (ii) This is ——— purse she presented me.
- (iii) The function was quite ——— success.
- (iv) ——— family sits for lunch.
- (v) This car runs at sixty kilometers ——— hour.

Part C

(3 × 10 = 30)

Answer **all** questions.

16. (a) What are Livingstone's views on education?

Or

(b) Write an essay on "On the Power of Youth".

17. (a) What are Gardiner's views on desirability or otherwise of forming habits?

Or

(b) What is the moral of the story "Crime and punishment? Elucidate.

18. (a) Fill in the blanks with correct adverbs from the box:
(usually, never, once, always, often, mostly, very, sometimes, occasionally, rarely)

- (i) I _____ go to bed at 10 O' clock.
- (ii) I have _____ been to the USA.
- (iii) I have been to Australia Just _____
- (iv) I _____ take a bath before I go to bed.
- (v) My grand-parents live in Kerala. I visit them _____
- (vi) My friends are _____ non-smokers.
- (vii) I was _____ impressed with her.
- (viii) I _____ go for a walk in the park.
- (ix) I watch English films _____
- (x) They _____ go out.

Or

(b) Fill in the blanks with appropriate prepositions :

- (i) The old man sat _____ the chair.
- (ii) He jumped _____ the wall.
- (iii) He has been singing here _____ 8 O' clock.
- (iv) He earned more _____ his sister.
- (v) He ran _____ the room.
- (vi) He is walking _____ the road.
- (vii) The pries knelt _____ the altar as the bride stood by him.
- (viii) _____ sweets the corporation building there is a hotel.
- (ix) He spoke _____ the independence of India.
- (x) The wholesaler gives commission _____ 25%.

C-6995

Sub. Code

91313

B.Sc. DEGREE EXAMINATION, NOVEMBER 2022.

First Semester

Aircraft Maintenance Science

MATHEMATICS

(2016 onwards)

Duration : 3 Hours

Maximum : 75 Marks

Part A

(10 × 2 = 20)

Answer **all** questions.

1. Write down the middle term of $(x - \frac{2}{x})^{12}$
2. Prove that $\left(\frac{1+x}{1-x}\right)^3 = 1 + 6x + 18x^2 + \dots$
3. Solve the equation $z^2 + |z| = 0$
4. Find $\lim_{x \rightarrow 0} \frac{x - \sin x}{x^3}$
5. Define homogeneous function.
6. If $u = (x - y)^4 + (y - z)^4 + (z - x)^4$, show that $\frac{\partial u}{\partial x} + \frac{\partial u}{\partial y} + \frac{\partial u}{\partial z} = 0$
7. Evaluate $\int (4 - 2x)^{-3} dx$

8. Evaluate $\int \frac{1}{e^x + 1} dx$
9. Define singular solution.
10. Solve $y = (x - a)p - p^2$

Part B

(5 × 5 = 25)

Answer **all** questions.

11. (a) Separate into partial fraction $\frac{4x^2 - 3x + 5}{(x + 1)(x^2 - 3x + 2)}$.

Or

- (b) Find the term independent of x in the expansion of $\left(\frac{4x^2}{3} - \frac{3}{2x}\right)^9$

12. (a) Solve approximately $\sin\left(\frac{\pi}{6} + \theta\right) = 0.51$

Or

- (b) Express $\cos 6\theta$ in terms of $\cos \theta$.

13. (a) If $u = \sin^{-1}\left(\frac{y}{x}\right)$, prove that $\frac{\partial^2 y}{\partial x \partial y} = \frac{\partial^2 y}{\partial y \partial x}$

Or

- (b) If $u = \frac{x^2 + y^2}{\sqrt{x + y}}$ then prove that $x \frac{\partial u}{\partial x} + y \frac{\partial u}{\partial y} = \frac{3}{2}z$.

14. (a) Evaluate $\int \frac{3x + 4}{(x - 7)(2x + 3)} dx$

Or

- (b) Evaluate $\int \frac{2x + 1}{x^2 + 3x + 1} dx$

15. (a) Solve $p^2 - 2py = 3y^2$ where $p = \frac{dy}{dx}$

Or

(b) Find the singular solution and general solution of the equation $y = 2px + y^2 p^3$

Part C (3 × 10 = 30)

Answer **all** questions.

16. (a) Find the coefficient of x^n in the expansion of $\frac{x-2}{(x+2)(x-1)^2}$ in ascending powers of x .

Or

(b) Find the sum to infinity of the series $\frac{5}{3.6} + \frac{5.7}{3.6.9} + \frac{5.7.9}{3.6.9.12} + \dots$.

17. (a) Express $\sin 7\theta$ in terms of $\sin \theta$

Or

(b) Prove that $\cos 5\theta = \frac{1}{16} [\cos 5\theta + 5 \cos 3\theta + 10 \cos \theta]$.

18. (a) (i) Find the n^{th} derivative $\sin^4 x \cos x^3$. (5)

(ii) If $u = \log(x^2 + y^2 + z^2)$, prove that $\frac{\partial^2 y}{\partial x^2} + \frac{\partial^2 y}{\partial y^2} + \frac{\partial^2 y}{\partial z^2} = \frac{4}{x^2 + y^2 + z^2}$. (5)

Or

(b) (i) Evaluate $\int \frac{dx}{\sqrt{x^2 - a^2}}$. (5)

(ii) Solve $p^2 - 2py = 3y^2$ where $p = \frac{dy}{dx}$. (5)

C-6996

Sub. Code

91314

B.Sc. DEGREE EXAMINATION, NOVEMBER 2022

First Semester

Aircraft Maintenance Science

WORKSHOP PRACTICES

(2016 onwards)

Duration : 3 Hours

Maximum : 75 Marks

Part A

(10 × 2 = 20)

Answer **all** questions.

1. How the tools are arranged in a workshop?
2. What are the general safe working practices to be followed in workshop?
3. Define tolerance.
4. What is the purpose of electrical general test equipment?
5. What is the purpose of the screw pitch gauge?
6. What is the use of the precision instruments?
7. What are two systems of fit for obtaining clearance, interference or transition fit?
8. Define allowance
9. Differentiate soldering and brazing.
10. What are the types of gears?

Part B

(5 × 5 = 25)

Answer **all** questions.

11. (a) What are the remedial actions to be taken when the Toxic chemical spill happens?

Or

- (b) Explain about the shop safety.

12. (a) Explain the following:

(i) Angle grinder

(ii) Nail gun.

Or

- (b) Explain about standards of workmanship

13. (a) Explain about the purpose and calibration of the vernier calipers. What is the procedure followed during calibration?

Or

- (b) Explain about:

(i) Vernier bevel protractor

(ii) Dial gauge.

14. (a) What are the types of brazing? Write short notes on brazing process.

Or

- (b) Write in detail about the classification of tolerance.

15. (a) What are the tools and equipment required for soldering process? Explain about it.

Or

- (b) What are the types of gear? Draw the diagram for the following

(i) Spur gear

(ii) Rack and pinion gear.

Part C

(3 × 10 = 30)

Answer **all** questions.

16. (a) Write the short notes on following
- (i) Workshop location
 - (ii) Arranging the tools in the workshop.

Or

- (b) Write in detail about any three of hand tools.

17. (a) Explain the following
- (i) Internal micrometer
 - (ii) External micrometer
 - (iii) Depth micrometer

Or

- (b) Write in detail about the gas welding process with suitable diagram.

18. (a) (i) What are the fits?
- (ii) Write in detail about the classification of the fits.

Or

- (b) Write a short note on following
- (i) Go and not go gauge
 - (ii) Screw pitch gauge

C-6997

Sub. Code

91315

B.Sc. DEGREE EXAMINATION, NOVEMBER 2022

First Semester

Aircraft Maintenance Science

BASIC ELECTRICITY

(2016 onwards)

Duration : 3 Hours

Maximum : 75 Marks

Part A

(10 × 2 = 20)

Answer **all** questions.

1. What are semiconductors?
2. Write down the nature of atoms.
3. Define Ohm's law.
4. What is parallel circuit?
5. Define resistors.
6. What is electric drive?
7. How can ammeter and voltmeter are connector in circuit?
8. What is multimeter?
9. Write down the EMF equation for DC generator.
10. Why commutator is employed in DC machine?

Part B

(5 × 5 = 25)

Answer **all** questions.

11. (a) State and explain the kirchhoff's law.

Or

- (b) Describe briefly energy band in solid charged particles.

12. (a) With the help of energy band diagrams, distinguish between insulators, metals and semiconductors.

Or

- (b) Explain the theory of magnetism?

13. (a) Explain the electrical circuit protection devices.

Or

- (b) Describe the electrical UPS.

14. (a) Discuss the advantages of a digital voltmeter over an analog voltmeter.

Or

- (b) Explain how time and frequency is measured using CRO.

15. (a) Drive the torque equation of D.C. motor.

Or

- (b) Explain the applications of DC generators.

Part C

(3 × 10 = 30)

Answer **all** questions.

16. (a) Discuss about the electrostatic focusing deflection system of a CRO with necessary diagram.

Or

- (b) Draw and explain load characteristics of DC shunt generator.

17. (a) Explain the working of operation of bridge rectifier circuit.

Or

- (b) A 4 pole wave wound generator having 40 slots and 10 conductors placed per slot. The flux per pole is 0.02wb. Calculate the generated emf when the generator is drive at 1200 rpm.

18. (a) Explain any three methods of producing voltage.

Or

- (b) For a circuit shown in figure. calculate the current in the 10 ohm resistance. Use thevenin's theorem only.

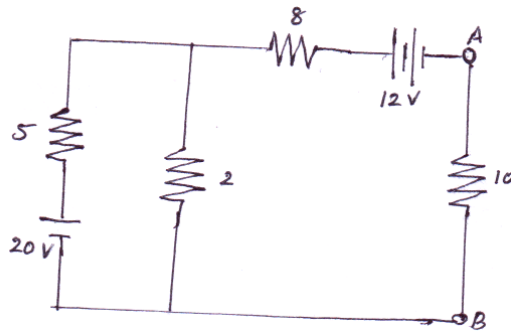

C-7023

Sub. Code

91421/22

U.G. DEGREE EXAMINATION, NOVEMBER 2022.

Second Year – Second Semester

Part II – English

**PROSE, EXTENSIVE READING AND COMMUNICATION
SKILLS**

(Common for all UG Degree Courses)

(2016 onwards to 2018 onwards)

Duration : 3 Hours

Maximum : 75 Marks

Part A

(10 × 2 = 20)

Answer **all** questions.

1. What is Forster's attitude towards Mr. Rumble?
2. How long did it take to make orthosis 300 gm callipers?
3. When did Indians first have the vision of freedom?
4. How did Gandhi become enshrined?
5. How was Lynd converted to nationalism?
6. What is discipline of reality?
7. What is the function of an adverb?
8. Give two example of pronouns.
9. Give two examples of demonstrative pronouns
10. What are three types of conjunctions?

Part B

(5 × 5 = 25)

Answer **all** questions.

11. (a) Write brief note on Dr. Kalam's third vision.

Or

- (b) What are the two ways in which science benefits man?

12. (a) How does Nehru close his speech?

Or

- (b) What is discipline of reality? How does a child learn realities?

13. (a) Comment on the theme of *After Twenty Years*.

Or

- (b) Write the note on the character sketch of the astrologer.

14. (a) Fill in the blanks by adding adverbial clauses.

(i) You will win his favour _____.

(ii) _____ he is strong.

(iii) This is good _____.

(iv) _____ we must try.

(v) We eat _____.

Or

- (b) Define types of pronouns with examples.

15. (a) Change into Direct speech:
- (i) Shivani asked me how I could lift it.
 - (ii) Leela ordered her servant not to clean it.
 - (iii) He said that Kevin should come.
 - (iv) She said that rain had fallen last night.
 - (v) He asked me where I lived.

Or

- (b) Write a short note on three types of comparisons.

Part C (3 × 10 = 30)

Answer **all** questions.

16. (a) Write an essay on the conflict between the state and the artist.

Or

- (b) Write about Dr. Kalam's contribution to Indian education.

17. (a) Sum up Plato's contradictory views on the artist's role in society.

Or

- (b) How does Nehru react to Gandhi's death? How does he finally reconcile himself to it?

18. (a) Explain Pronoun and its kinds with example.

Or

- (b) Write short notes on adverbial clauses and its types with examples.

C-5655

Sub. Code

91323

B.Sc. DEGREE EXAMINATION, APRIL 2022

Second Semester

Aircraft and Maintenance Science

APPLIED PHYSICS

(2016 onwards)

Duration : 3 Hours

Maximum : 75 Marks

Part A

(10 × 2 = 20)

Answer **all** questions.

1. What is thin film?
2. State Brewster's law for reflection.
3. Write down Sabine formula and Define reverberation time.
4. Define population Inversion.
5. Define Miller Indices.
6. What are Newton rings?
7. Define length contraction.
8. What is holography?
9. List out types of optical Fibres.
10. State Meissner effect.

Part B

(5 × 5 = 25)

Answer **all** questions.

11. (a) Explain in detail plane parallel thin films.

Or

- (b) Write a short note diffraction grating.

12. (a) Explain in detail dispersion in Nicol Prism.

Or

- (b) With neat sketch explain the Lorentz transformations.

13. (a) Briefly explain reverberation theory.

Or

- (b) Write a short note: Non Destructive Test.

14. (a) Describe in detail Ruby laser.

Or

- (b) Define total internal reflection and explain the propagation of light through a fibre cable.

15. (a) Write a short note: Superconductivity.

Or

- (b) Write a short note: Crystal defects.

Part C

(3 × 10 = 30)

Answer **all** questions.

16. (a) Explain in detail, how you will calculate the Miller Indices of the crystalline structures.

Or

- (b) What is meant by radiative and non-radiative transitions? With neat illustration explain in detail semiconductor laser.
17. (a) Derive Sabine's formula for a Hall and let your suggestions about acoustic materials.

Or

- (b) Explain in detail Fraunhofer diffraction using single slit method.
18. (a) With neat illustration explain in detail inertial and non inertial frame of reference.

Or

- (b) Explain the principle and working of recording and re-recording of Holography technique.

C-5656

Sub. Code

91324

B.Sc. DEGREE EXAMINATION, APRIL 2022

Second Semester

Aircraft Maintenance Science

**PRINCIPLE OF ELECTRONICS AND ELECTRONICS
CIRCUITS**

(2016 onwards)

Duration : 3 Hours

Maximum : 75 Marks

Part A

(10 × 2 = 20)

Answer **all** questions.

1. Define resistor.
2. Compare inductance with capacitances.
3. What is intrinsic semiconductor?
4. What is a transistor?
5. Write a note on classification of amplifier.
6. Write a feature of power amplifier.
7. What is an oscillator?
8. What is clap oscillator? What is its practical merit?
9. What are the important characteristics of OP-AMP?
10. Define the term logic gate.

Part B

(5 × 5 = 25)

Answer **all** questions.

11. (a) What is the principal difference between adjustable and variable resistors?

Or

- (b) Describe the time constant for capacitors.

12. (a) What is a P-N junction? Explain clearly its properties.

Or

- (b) Explain the difference transistor configuration.

13. (a) Derive an expression for the effect of Class B power amplifier.

Or

- (b) Draw the circuit for a push pull amplifier and discuss its working.

14. (a) Explain Barkhausen criterion for sustained oscillations.

Or

- (b) Discuss the relative merits and demerits of the different types of oscillators.

15. (a) Explain briefly about half adder with their expression, truth table.

Or

- (b) Describe working principles of radio transmission.

Part C

(3 × 10 = 30)

Answer **all** questions.

16. (a) For a JFET having $g_m = 6\text{mS}$ at $V_{gs} = -1\text{V}$, find the value I_{DSS} , if $V_p = -2.5\text{V}$.

Or

- (b) Give $I_{DSS} = 9\text{mA}$ and $V_p = -3.5\text{V}$. find I_D , when
(i) $V_{gs} = 0$, (ii) $V_{gs} = -2\text{V}$, (iii) $V_{gs} = -3.5\text{V}$
(iv) $V_{gs} = -5\text{V}$
17. (a) What reason will you assign for higher conversion effect of class B amplifier as compared to class A amplifier?

Or

- (b) Explain with necessary diagram, the operation of Hartley oscillator.
18. (a) Draw and explain the performance characteristics of SCR.

Or

- (b) State and verify De Morgan's theorems.

C-7000

Sub. Code

91332

B.Sc. DEGREE EXAMINATION, NOVEMBER 2022

Third Semester

Aircraft Maintenance Science

**STRENGTH OF MATERIALS AND APPLIED
MECHANICS**

(2016 onwards)

Duration : 3 Hours

Maximum : 75 Marks

Part A

(10 × 2 = 20)

Answer **all** questions.

1. Define period
2. Write a short note on derived units.
3. Define strain.
4. What is elastic limit?
5. What are the sign conventions for calculating shear force and bending moment in the beam?
6. Name the theories of failure of the structure.
7. Define factor of safety.
8. What are the types of springs?
9. Define BIS.
10. What is the use of the gear drive?

Part B

(5 × 5 = 25)

Answer **all** questions.

11. (a) Define the following:
- (i) Fundamental units
 - (ii) Mechanics
 - (iii) Triangle law of forces

Or

- (b) Define the following:
- (i) Polygon law of forces
 - (ii) Composition of forces
 - (iii) kinetics

12. (a) Derive the expression for deformation of a bar due to its own weight.

Or

- (b) Define the following
- (i) Principle of superposition.
 - (ii) Differentiate compressive stress and shear stress.

13. (a) A cantilever of length 4 m carries a uniformly distributed load of 2.5 KN/m run over a length of 1.5 m from the fixed end. And also, it carries a point load of 3 KN at a distance of 2 m from fixed end. Draw the shear force and bending moment diagrams

Or

- (b) Write about maximum principal strain theory.
14. (a) Define the following
- (i) Riveted joint
 - (ii) Lap joint
 - (iii) Butt joint

Or

- (b) What are the types of bearing? where bearings are used?
15. (a) Discuss about the gear drives briefly.

Or

- (b) Different types of fasteners used in aircraft

Part C (3 × 10 = 30)

Answer **all** questions.

16. (a) Derive the formula for change in length (dL) of bars of varying section.

Or

(b) Define the following:

- (i) Mechanics
- (ii) Space
- (iii) Fundamental units
- (iv) Time
- (v) Scalar

17. (a) A steel wire ABC 16 m long having cross-sectional area of 4 mm^2 weighs 20 N as shown in Fig. If the modulus of elasticity for the wire materials is 200 GPa, find the deflections at C and B.

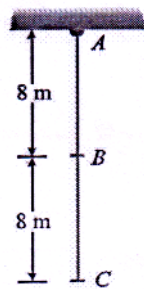

Or

- (b) Derive the expression for slope and deflection of cantilever beam carrying a point load at a free end.

18. (a) Explain about the procedure for riveting process.

Or

- (b) Explain about the belt drives and derive the expression for the span of the belt.

C-7001

Sub. Code

91333

B.Sc. DEGREE EXAMINATION, NOVEMBER 2022

Third Semester

Aircraft Maintenance Science

FLUID MECHANICS AND HYDRAULIC MACHINES

(2016 onwards)

Duration : 3 Hours

Maximum : 75 Marks

Part A

(10 × 2 = 20)

Answer **all** questions.

1. Define compressibility.
2. Define Elasticity.
3. What do you mean by fluid discharge? What is the unit for this?
4. Write down the expression for Bernoulli's equation.
5. State the Darcy weisbach formula for head loss due to friction.
6. Draw the diagram for Venturi meter and mention its parts.
7. What are the advantages of reciprocating pump?
8. Write down the classification of the turbine?
9. What is hydraulic accumulator?
10. Write some of the hydraulic circuit components.

Part B

(5 × 5 = 25)

Answer **all** questions.

11. (a) What is manometer? Write about the inverted U tube manometer with suitable sketch and also state the expression to find the gauge pressure.

Or

- (b) A single column manometer is connected to a pipe containing a liquid of sp.gr. 0.9 as shown in Fig. Find the pressure in the pipe if the area of the reservoir is 90 times the area of the tube for the manometer reading shown in fig. The specific gravity of mercury is 13.6.

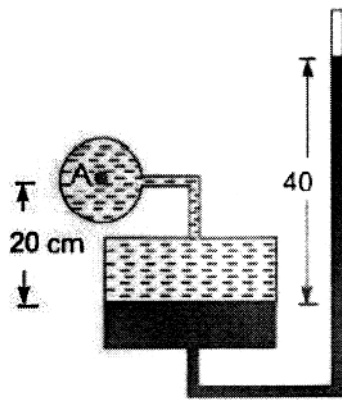

12. (a) Derive the Euler's equation of motion.

Or

- (b) A 40cm diameter pipe, conveying water, branches into two pipes of diameters 30 cm and 20 cm respectively. If the average velocity in the 40 cm diameter pipe is 3m/s. Find the discharge in this pipe. Also determine the velocity in 20 cm pipe if the average velocity in 30cm diameter pipe is 2 m/s.

13. (a) A pipe of dia. 300mm and length 3500 m is used for the transmission of power by water. The total head at the inlet of the pipe is 500 m. Find the maximum power available at the outlet of the pipe, if the value of $f = 0.006$.

Or

- (b) Explain about the water hammer in pipe during gradual closure of valves.
14. (a) Write about the centrifugal pump with suitable diagrams.

Or

- (b) Write the classification of the turbine. Explain about the radial flow reaction turbine.
15. (a) Write about hydraulic lift.

Or

- (b) Write about the hydraulic coupling with suitable diagram.

Part C

(3 × 10 = 30)

Answer **all** questions.

16. (a) Type of valve and controls used in hydraulic and pneumatic systems.

Or

- (b) A differential manometer is connected at the two points A and B of two pipes as shown in Fig. The pipe A contains a liquid of sp.gr. = 1.5 while pipe B contains a liquid of sp.gr. = 0.9. The pressure at A and B are 1 kgf/cm^2 and 1.80 kgf/cm^2 respectively. Find the difference in mercury level in the differential manometer.

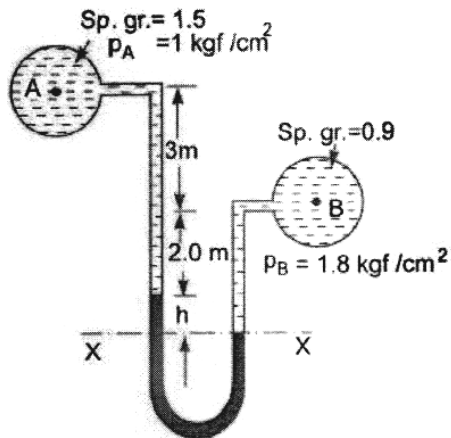

17. (a) Write about any one of fluid system with suitable sketch.

Or

- (b) Write in detail about hydroelectric power plant.

18. (a) Write about types of fluid flow in detail.

Or

- (b) Write about the venturi meter and state the expression for coefficient of discharge.

C-7002

Sub. Code

91334

B.Sc. DEGREE EXAMINATION, NOVEMBER 2022

Third Semester

Aircraft Maintenance Science

**MECHANICS OF FLIGHT AND HELICOPTER
CONFIGURATION**

(2016 onwards)

Duration : 3 Hours

Maximum : 75 Marks

Part A

(10 × 2 = 20)

Answer **all** questions.

1. What is adiabatic lapse rate?
2. Define angle of attack.
3. What is meant by lift/drag ratio?
4. Define induced drag.
5. What is a helicopter?
6. What is meant by the term blade conning?
7. Define mast.
8. Mention the types of dampeners.
9. What are the major components of tail rotor gear box?
10. Define clutch.

Part B

(5 × 5 = 25)

Answer **all** questions.

11. (a) In simple terms, explain Bernoulli's principle

Or

- (b) Explain four airfoil characteristics.

12. (a) What is lift force? Explain the fundamental equation for lift.

Or

- (b) Describe the three axes of an airplane with neat sketch.

13. (a) Describe the Coriolis effect and explain how it affects the rotor blades.

Or

- (b) Explain the concept of autorotation.

14. (a) Explain in detail about swash plate mechanism.

Or

- (b) Explain the procedure for rotor head maintenance.

15. (a) Explain in detail about the engine transmission couplings.

Or

- (b) Discuss briefly about the freewheeling units.

Part C

(3 × 10 = 30)

Answer **all** questions.

16. (a) Briefly discuss the factors contributing lift generation.

Or

- (b) Explain in detail about the various secondary control surfaces.

17. (a) Explain the forces acting on a helicopter flight.

Or

- (b) Explain in detail about blade alignment and static main rotor balance.

18. (a) Explain briefly about the flight control systems.

Or

- (b) Explain in detail about the major components of the tail rotor drive shaft system.

C-7003

Sub. Code

91335

B.Sc. DEGREE EXAMINATION, NOVEMBER 2022

Third Semester

Aircraft Maintenance Science

AIRCRAFT MATERIALS, HARDWARE AND NDT

(2016 onwards)

Duration : 3 Hours

Maximum : 75 Marks

Part A

(10 × 2 = 20)

Answer **all** questions.

1. Define elastic limit.
2. Write down the composition of Inconel and Rene 41.
3. Define annealing.
4. What are the types of corrosion?
5. What is an MIL specification?
6. Write down the advantages of lock bolts.
7. Mention the function of matrix materials in composites.
8. What is Kevlar?
9. List down the advantages of boroscope inspection.
10. Define fatigue.

Part B

(5 × 5 = 25)

Answer **all** questions.

11. (a) What alloying elements are used in 18-8 stainless steels?

Or

- (b) What are the advantages of magnesium for aircraft parts?

12. (a) Describe how case hardening of steel is accomplished?

Or

- (b) Write short on metal spraying process.

13. (a) What types of wood are considered standard for aircraft structures.

Or

- (b) What is the difference between a standard machine screw and a structural screw?

14. (a) Explain in detail about the various fiber materials used in composite materials.

Or

- (b) Describe the honeycomb core material.

15. (a) Explain the testing procedure in Brinell hardness test.

Or

- (b) How is Penetrant inspection accomplished?

Part C

(3 × 10 = 30)

Answer **all** questions.

16. (a) Describe the composition and properties of aluminum alloys 7075 T6.

Or

- (b) Explain the heat treatment of ferrous materials.

17. (a) Explain the principle of a fiber locknut.

Or

- (b) Briefly explain about the plastics and its classifications.

18. (a) What are Prepregs? Write the advantages of using Prepregs.

Or

- (b) Explain the principle and process involved in ultrasonic inspection

C-7004

Sub. Code

91342

B.Sc. DEGREE EXAMINATION, NOVEMBER 2022

Fourth Semester

Aircraft Maintenance Science

THERMODYNAMICS

(2016 onwards)

Duration : 3 Hours

Maximum : 75 Marks

Part A

(10 × 2 = 20)

Answer **all** questions.

1. Write the three modes of heat transfer?
2. Define Entropy”
3. What is called refrigeration cycle?
4. Write the importance of pressure ratio in Otto cycle?
5. What is Dalton’s law?
6. Write the difference between fuel and combustion?
7. Write the equation of power required to run the compressor?
8. Define Isothermal efficiency of reciprocating compressor?
9. Write the basic principles of gas turbine propulsion?
10. Define thrust equation?

Part B

(5 × 5 = 25)

Answer **all** questions.

11. (a) Write the importance of SFEE and its applications?

Or

- (b) What is control volume Technique?

12. (a) Write short notes on vapour compression refrigeration cycle?

Or

- (b) What do understand of absorption refrigeration cycle?

13. (a) Write basic theory of compressing air?

Or

- (b) Write short notes on rotary screw compressor?

14. (a) Write the Compressors in ideal thermodynamic cycles?

Or

- (b) List out few applications of compressors?

15. (a) What is the purpose of crankshaft in piston engine and its parts.

Or

- (b) What is the purpose of combustion chamber in gas turbine engine?

Part C

(3 × 10 = 30)

Answer **all** questions.

16. (a) Briefly explain about the basic components of Reciprocating aircraft engine?

Or

- (b) Discuss about the various components in vapor absorption refrigeration plant?

17. (a) Write short notes on (i) Carnot Cycle
(ii) Dual Cycle?

Or

- (b) List out and explain the classifications of air compressors?

18. (a) Briefly explain about the axial flow compressors in gas turbine engine?

Or

- (b) Write notes on Rocket Propulsion?
-

C-7005

Sub. Code

91343

B.Sc. DEGREE EXAMINATION, NOVEMBER 2022

Fourth Semester

Aircraft Maintenance Science

AIRCRAFT INSTRUMENTS AND COMPASS

(2016 onwards)

Duration : 3 Hours

Maximum : 75 Marks

Part A

(10 × 2 = 20)

Answer **all** questions.

1. Define static counter display.
2. Define stratosphere.
3. Define airspeed indicator.
4. What is Machmeter?
5. Define the terms of Longitude.
6. Define turn to slip indicator.
7. Write the probe.
8. What is the principle of thermocouple?
9. Define soft iron magnetism.
10. What is magnetic meridian?

Part B

(5 × 5 = 25)

Answer **all** questions.

11. (a) Show how the principle of LED applied to produce a segmented numerical display?

Or

- (b) What do you understand by term ISA? State also the assumption made.

12. (a) Explain the stall warning system in large aircraft?

Or

- (b) What is the difference between pressure altitude and indicated altitude?

13. (a) Describe the principle and working operation of directional gyroscope?

Or

- (b) Briefly explain the two properties of gyroscopic?

14. (a) Explain the types of thermocouple sensors?

Or

- (b) Explain in details about torque monitoring with sketch of torque meter?

15. (a) Describe the construction features of DR compass?

Or

- (b) Describe the construction of a compass?

Part C

(3 × 10 = 30)

Answer **all** questions.

16. (a) Describe the operating of wheat stone bridge with neat sketch?

Or

- (b) Explain briefly about quantitative displays?

17. (a) Describe the principle and operation of engine pressure ratio indicator.

Or

- (b) Write down the features briefly about the vertical speed indicators?

18. (a) Explain the principle and operation of altimeter?

Or

- (b) Describe the operation of turn to slip indicator?

C-7006

Sub. Code

91344

B.Sc. DEGREE EXAMINATION, NOVEMBER 2022

Fourth Semester

Aircraft Maintenance Science

AIRCRAFT STRUCTURE AND SYSTEMS

(2016 onwards)

Duration : 3 Hours

Maximum : 75 Marks

Part A

(10 × 2 = 20)

Answer **all** questions.

1. What is the function of stringers
2. List four types of station numbers
3. Name the secondary control surface
4. What are the features of fly by wire system?
5. State the types of landing gear
6. What is the function of the piston type shimmy dampers
7. Which of the types of fluids do not mix together?
8. What is the purpose and necessity of the pressure relief valve?
9. What are the main components in the fuel system?
10. What is the purpose of fuel jettisoning system?

Part B

(5 × 5 = 25)

Answer **all** questions.

11. (a) Write in detail about semi monocoque.

Or

- (b) What do you mean by fail safe components used in aircraft and what are their advantages when used in aircraft?

12. (a) How does the yaw control achieve? Explain with suitable diagram.

Or

- (b) What are the secondary control surfaces used in a passenger aircraft and what are their functions?

13. (a) Explain about electrical retraction system and emergency landing gear extension system.

Or

- (b) Explain about power boost brake system

14. (a) What is purpose of the reservoir and it's types? Explain about the operation of the reservoir in the hydraulic system.

Or

- (b) Discuss about the selector valves with suitable diagram.

15. (a) Discuss with the neat diagram of the gravity feed fuel system.

Or

- (b) Discuss about the pressure feed fuel system with neat sketch.

Part C

(3 × 10 = 30)

Answer **all** questions.

16. (a) Write short note on following:
- (i) Forces acting in an aircraft.
 - (ii) Sandwich construction and their application

Or

- (b) Explain about fly by wire system with suitable diagrams.
17. (a) Write in detail about Inspection and maintenance of the control surface and control system.

Or

- (b) What is the purpose of the accumulator? Explain about its types.
18. (a) Draw the schematic of the hydraulic system layout. Explain about the various components in it.

Or

- (b) Explain about the types fuel tanks in the aircraft.
-